

| SN | Version | Detail | Name | Date | DSN | Version | Detail | Name | Date |
|----|---------|--------|------|------|-----|---------|--------|------|------|
| 3 | | | | | 1 | | | | |
| 4 | | | | | 2 | | | | |

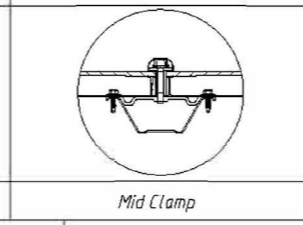
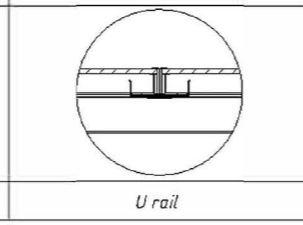
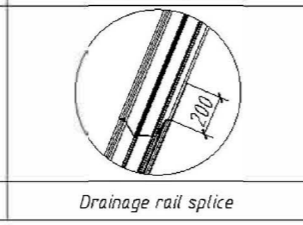
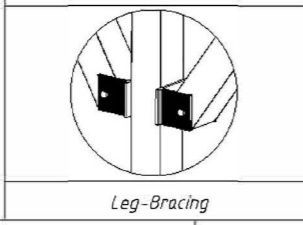
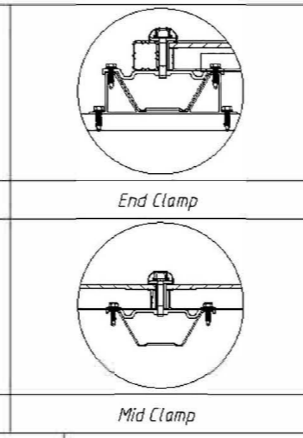
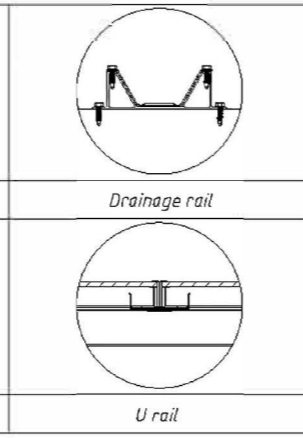
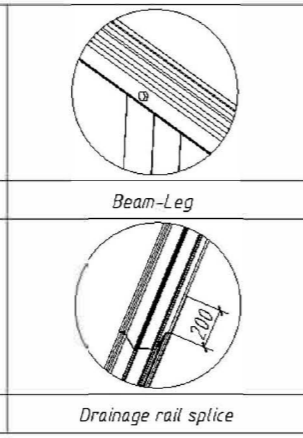
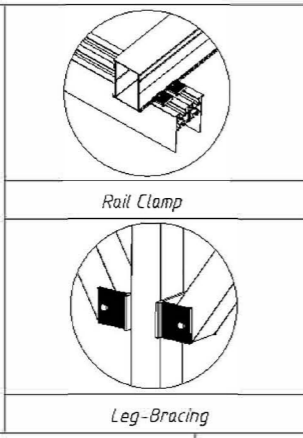
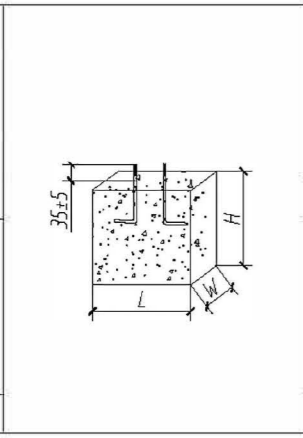
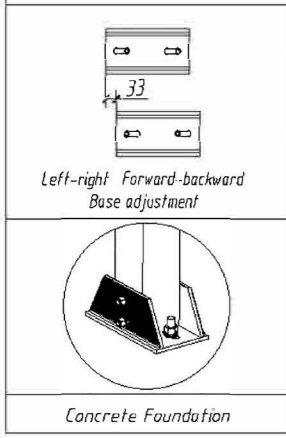
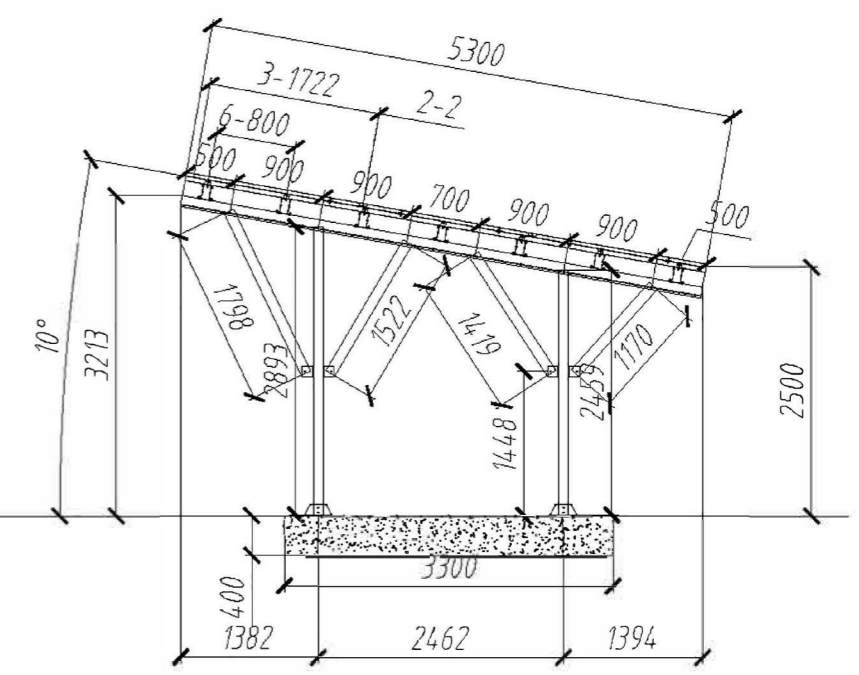
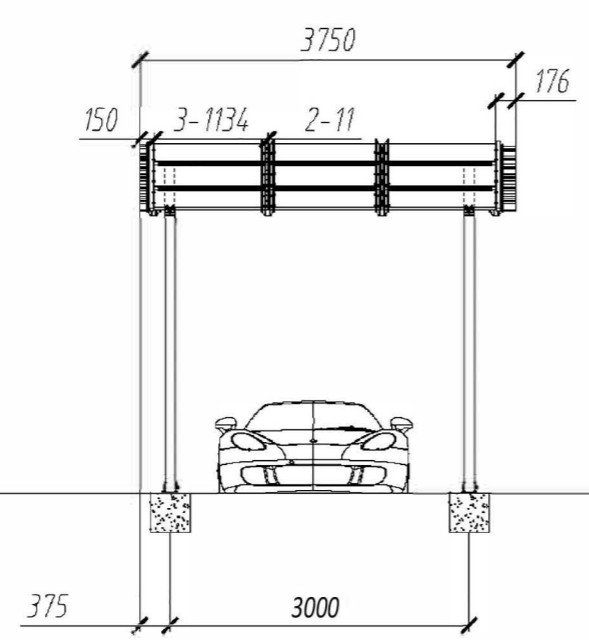

| | | | |
|--------------|--|-------------------|---|
| Project Info | Czech-NNS-Residential Carport-207.37kw | | |
| Racking Type | | | |
| Panel Size | 1722x1134x30 | | |
| Wind Speed | 30m/s | Snow Load | 0 |
| Design | Kimi | Surface Roughness | B |
| Confirm | Abel | 3x3 | |
| Approval | Abel | | |

| | | | |
|----------|----------------|---------|----------|
| Standard | BS-EN | Version | V1.0 |
| Material | 6005-T6+SUS304 | | |
| Page | 1 / 1 | Date | 23/11/10 |

| SN | Version | Detail | Name | Date | DSN | Version | Detail | Name | Date |
|----|---------|--------|------|------|-----|---------|--------|------|------|
| 3 | | | | | 1 | | | | |
| 4 | | | | | 2 | | | | |

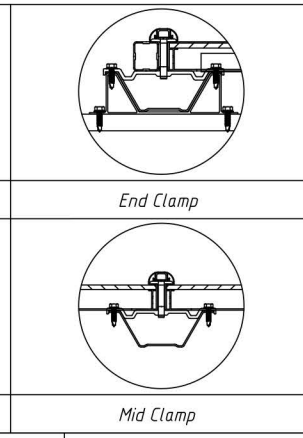
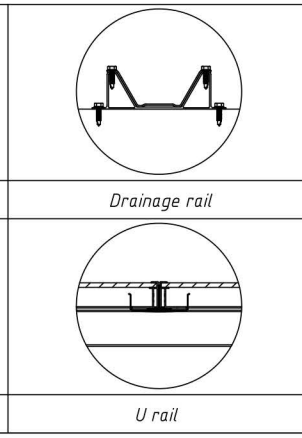
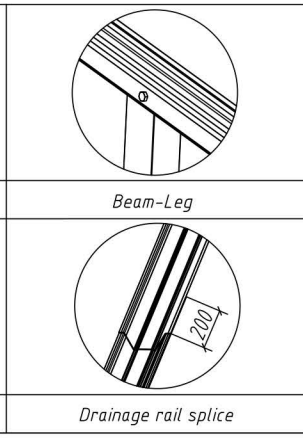
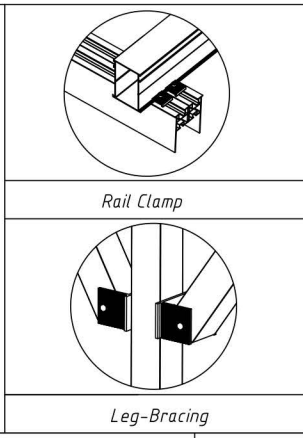
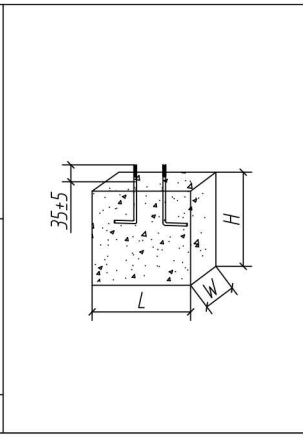
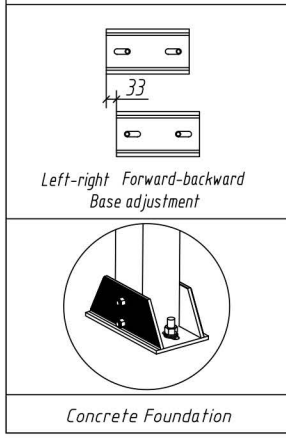
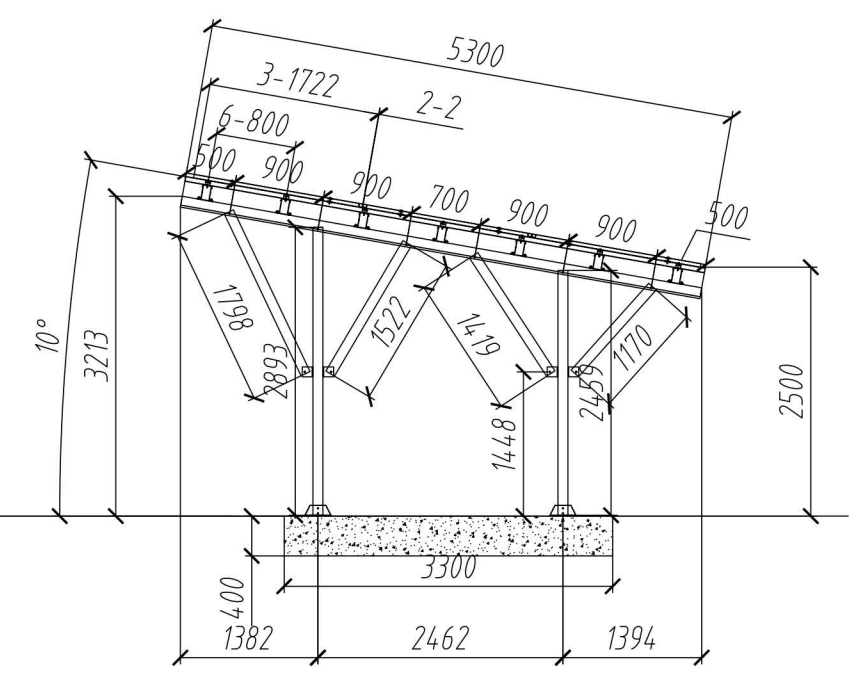
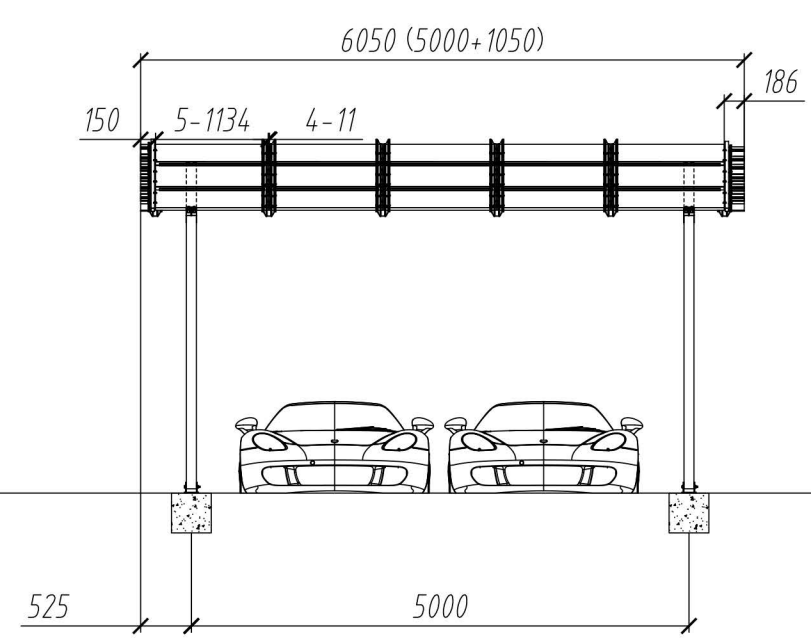

| | | | |
|--------------|--|-------------------|---|
| Project Info | Czech-NNS-Residential Carport-207.37kw | | |
| Racking Type | | | |
| Panel Size | 1722x1134x30 | | |
| Wind Speed | 30m/s | Snow Load | 0 |
| Design | Kimi | Surface Roughness | B |
| Confirm | Abel | 3x5 | |
| Approval | Abel | | |



the cost effective solar mounting

| | | | |
|----------|----------------|---------|----------|
| Standard | BS-EN | Version | V1.0 |
| Material | 6005-T6+SUS304 | | |
| Page | 1 / 1 | Date | 23/11/10 |